

ASSEMBLY INSTRUCTIONS FOR YOUR TOY BOX BENCH

Thank you for your purchase of the Toy Box Bench. We know that it will bring you and your little one years of enjoyment. **PLEASE READ ALL INSTRUCTIONS THOROUGHLY BEFORE BEGINNING ASSEMBLY.**

General Safety Instructions:

- Your Toy Box Bench is safety tested for all ages.
- However, it is recommended that caution be used at all times.
- Recommended for children up to 100lbs
- Must be assembled by an adult. Do not leave any spare parts near children.**
- Caution: Although a safety hinge is installed, be careful when opening and closing the lid to avoid injury to small children.**

What tools you will need?

- Standard Philips head screwdriver. CAUTION: It is highly recommended that you not use power tools or electric screwdrivers as screws should not be over-tightened. Power/electric tools may strip either the screw or the receiving end of the screw.

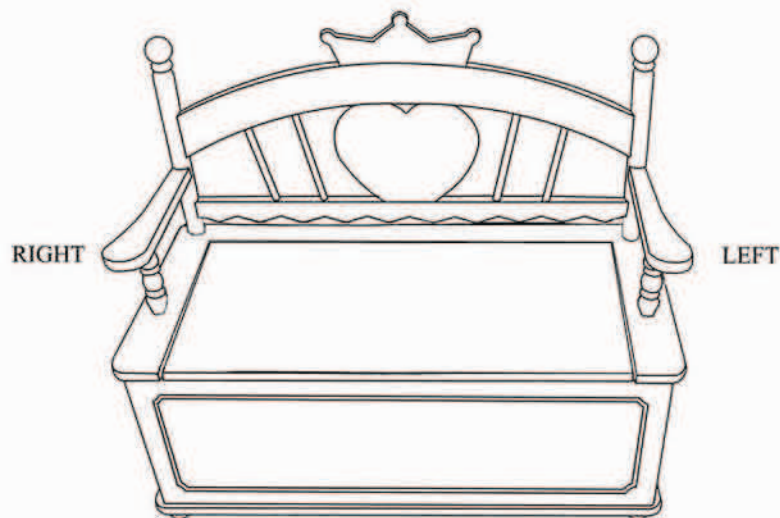

(Your toy box bench shape may be different the drawing above)

Note: In the directions, left and right refer to the side of the chair as if you were standing behind the bench.

WARNING:

Products shall be assembled by adult. Product contains sharp point, sharp edge and small parts before assembled. Keep out of child's reach when Products unassembled.

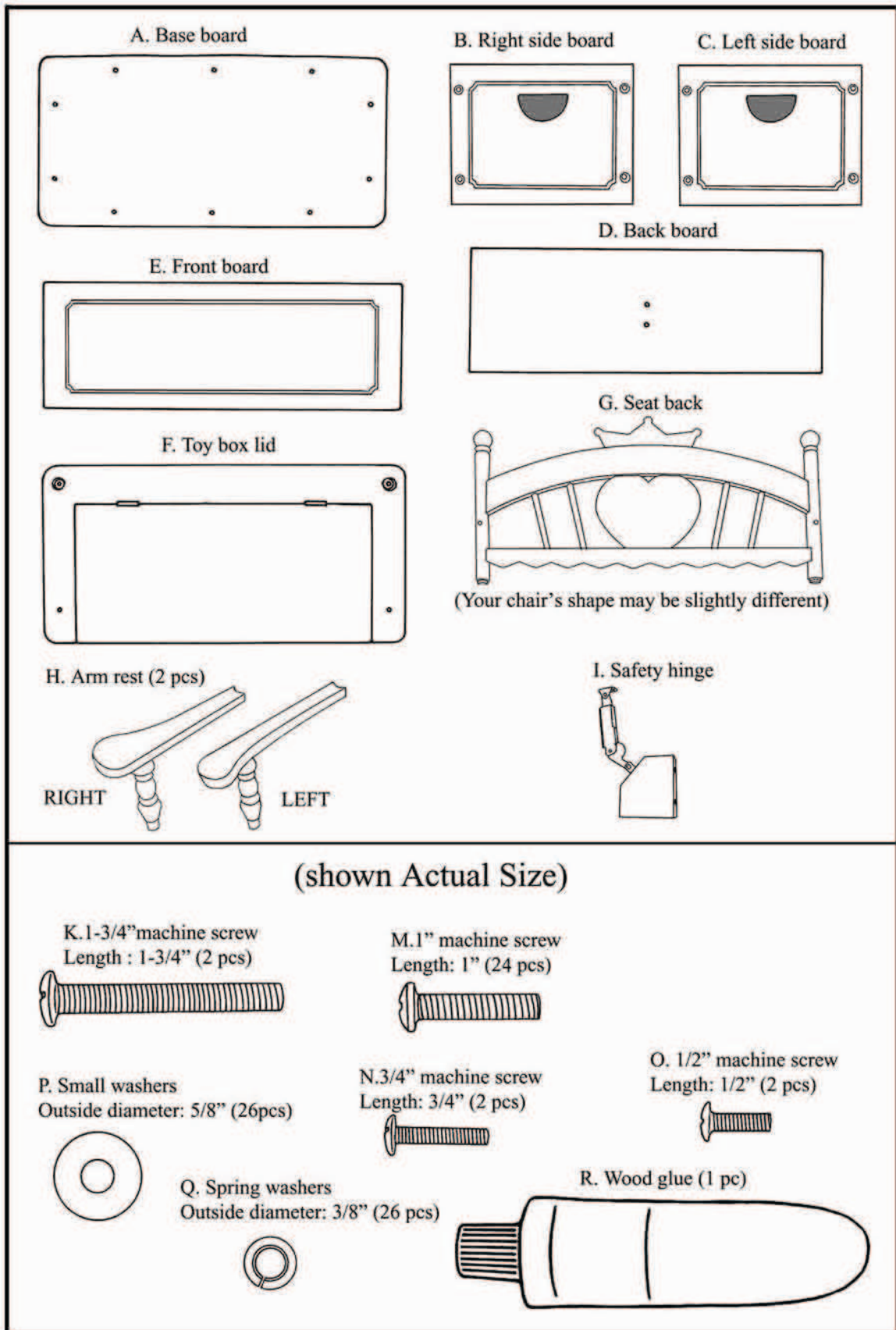

ASSEMBLY PROCEDURE

1. Prior to assembling each wooden part, liberally apply the wood glue from the supplied bottle (R) to both wooden parts. After assembly (and before glue dries) wipe off any excess glue. While not absolutely necessary, the glue will add additional strength to each joint and is recommended.
2. To save time, we suggest that you organize and pre-assemble in the sequence shown in the Fig. Drawings all of the screws and their washers.

Fig. 1 Assemble seat back (G) and toy box lid (F)

- Place the box lid (F) on the floor with the design facing to the top.
- Insert the posts on the seat back (G) into the pre-drilled holes on the toy box lid.
- Insert 1" machine screws (M) through spring washers (Q) and small washers (P) and tighten securely.

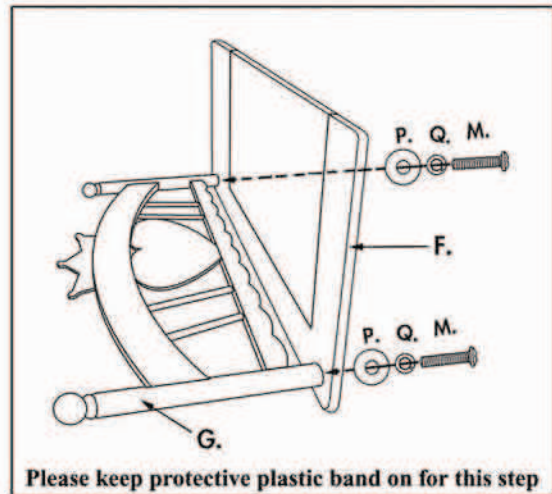
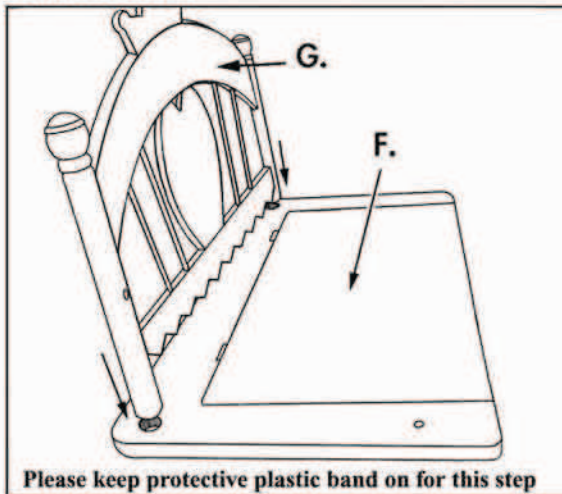

Fig. 2 Assemble the safety hinge (I) to the back side board (D)

- Insert 3/4" machine screws (N) into pre-drilled holes on the back board (D) and secure the safety hinge by tightening the screw.
- Please see Fig drawing for proper alignment and positioning of the safety hinge (I).

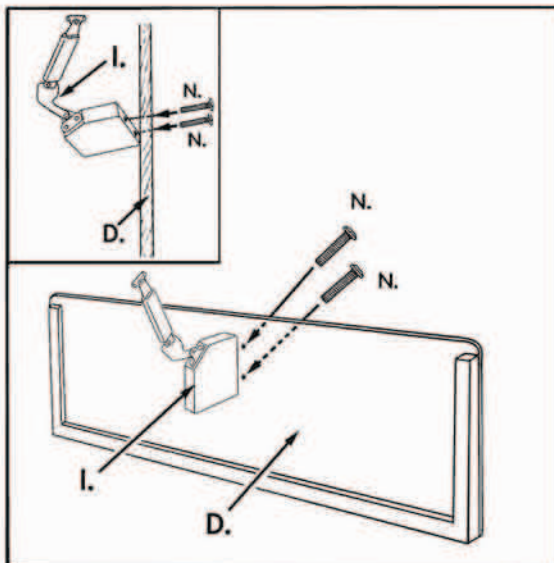

Fig. 3 Assemble the toy box lid assembly (F) to right and left side boards (B, C)

- Remove the protective plastic strap from the box lid and gently raise the hinged lid (F) until it comes in contact with the seat back (G). Do not let the lid (F) hit hard against the seat back (G) or it may be scratched or damaged!
- Lay the toy box lid assembly on a soft surface with the seat back resting on the floor. Place the right side board (B) next to the pre-drilled holes on the toy box lid.
- Insert the 1" machine screws (M) through spring washers (Q) and small washer (P) and tighten securely
- Repeat the procedure to assemble left side board (C).

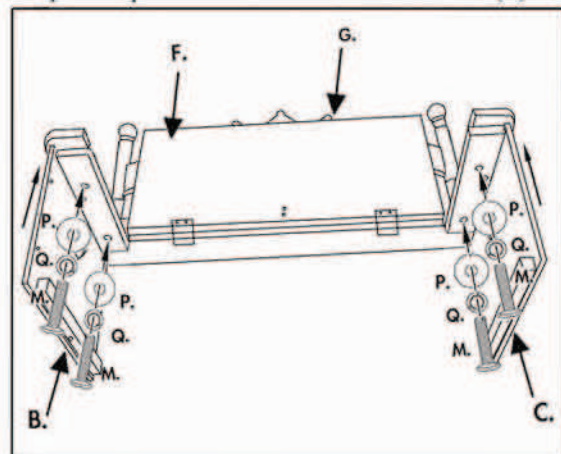

Fig. 4 Attach the back board (D)

- Place the back board (D) on the assembly.
- Insert the 1" machine screws (M) through the spring washers (Q) small washers (P) and tighten securely into all pre-drilled holes.

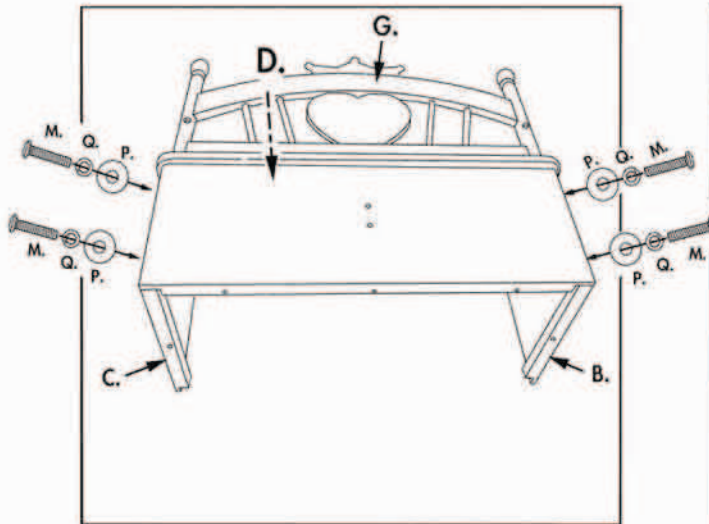

Fig. 5 Attach the safety hinge (I) to the toy box lid (F)

- Insert 1/2" machines screw (O) into pre-drilled holes on the safety hinge.
- Tighten screws securely.

1. If the safety hinge (I) is not assembled, the lid will fall by itself and will cause danger to children.
2. After the safety hinge (I) is assembled, the lid will not fall by itself when it is opened.

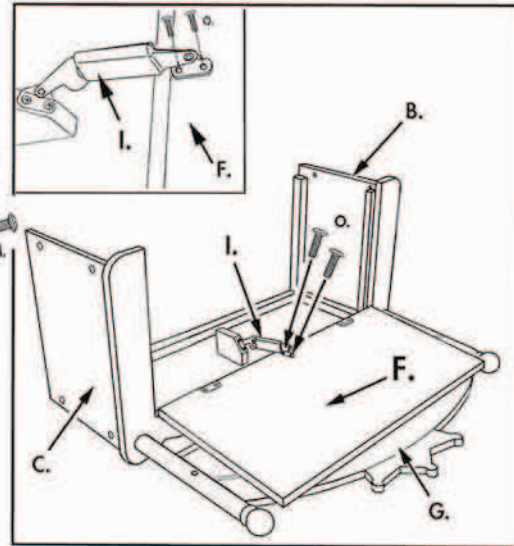

Fig. 6 Assemble the arm rests (H) to the toy box lid (F) and seat back (G)

- Apply glue (R) to the predrilled holes on both ends of armrests.
- Align each arm with the pre-drilled hole on the toy box lid.
- Insert 1" machine screw (M) through spring washer (Q) and small washer (P) and tighten securely to assemble the toy box lid (F).
- Insert 1-3/4" machine screw (K) through spring washer (Q) and small washer (P) and securely tighten with Philips head screwdriver to assemble the seat back (G).

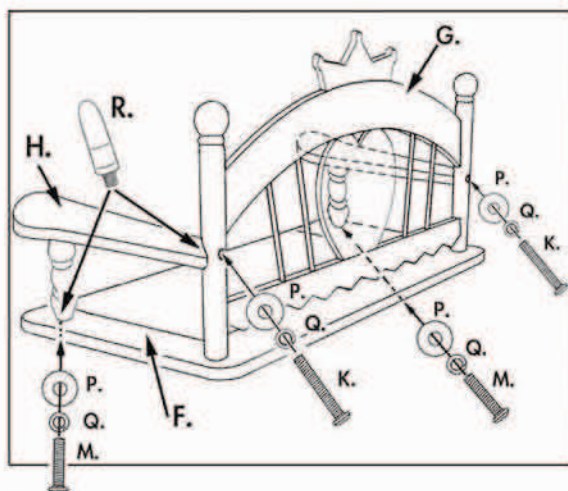
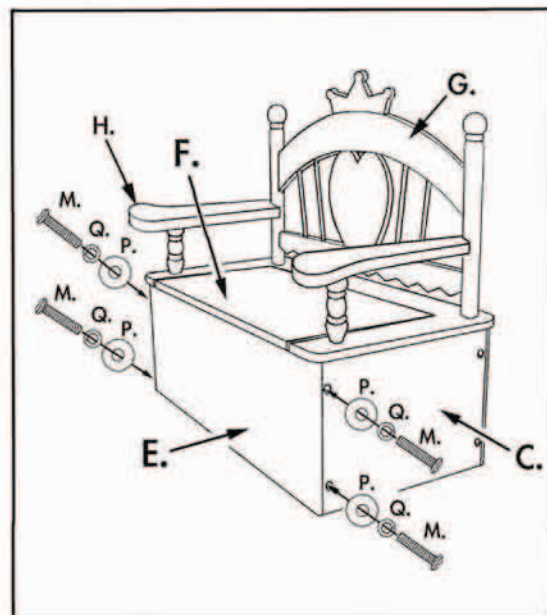

Fig. 7 Attach the front board (E)

- Line up the front board with the cloud design facing the front. The thicker side should be on the bottom.
- Insert the 1" machine screws (M) through the spring washers (Q) small washers (P) and tighten securely into all pre-drilled holes.



Note: Please make sure safety hinge (I) is properly installed on (D) and (F). It is the main supporter of toy box lid which slows the lid while closing. If this safety hinge is not installed, it might cause any unnecessary hazard.

Fig. 8 Attach the base board (A)

- Place the assembly as show in the drawing below.
- Attach the base board to the assembly.
- Insert the 1" machine screws (M) through the spring washers (Q) and the small washers (P) and tighten securely into all pre-drilled holes.

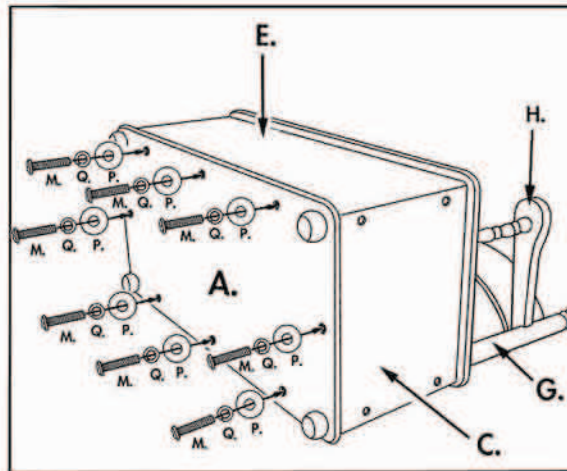

Finally, please check that all parts are tightened securely but **do not overtighten**. Your Toy Box Bench piece should now be ready to use. Enjoy!

Please visit our website and discover all our other innovative and fun products for kids at:

www.levelsofdiscovery.com

Toy Box Bench
© 2002 Levels of Discovery LLC
Roselle, Illinois 60172

Made in China
Printed in China